

FITTING INSTRUCTION

Clamp mark in acc. with		Cables joining
ISO	PN	
1	L	Left directional lights
2	+	Rear fog lights
3	31	Ground
4	R	Right directional lights
5	58R	Right side parking lights
6	54	Stoplights
7	58L	Left side parking lights

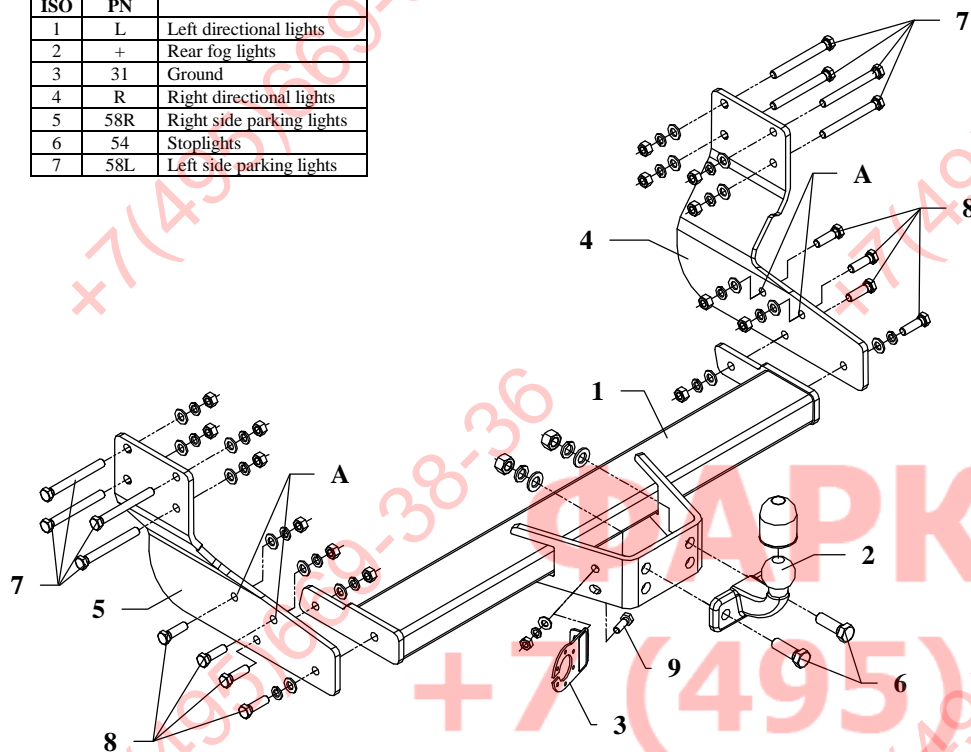

This towbar is designed to assembly in following cars: **MERCEDES SPRINTER** and **VOLKSWAGEN CRAFTER**, 3,25/3,665/4,325m, metal built-up, with step board, single wheels, produced since 04.2006, catalogue no. **D34** and is prepared to tow trailers max total weight **2800 kg** and max vertical load **100 kg**.

From manufacturer

Thank you for buying our product. Their reliability has been confirmed in many tests. Reliability of towbar depends also on correct assembly and right operation. For this reasons we kindly ask to read carefully this instruction and apply to hints.

The towbar should be install in points described by a car producer.

The instruction of the assembly

1. For the purpose of installing of the towbar one should twist off and replace factory bolts holding the step board on the bolts M12x110mm (pos. 7) from the towbar accessories. These bolts one ought to put from the internal side of the frame.
2. On so prepared bolts one ought to put brackets of the towbar (pos. 4 and 5) and fix.
3. Between brackets of the towbar (pos. 4 and 5) slip the main bar of the towbar (pos. 1) and fix using bolts M12x40mm (pos. 8).
4. Through holes (pos. A) of brackets (pos. 4 and 5) and the bracket of the step drill holes $\varnothing 13\text{mm}$ and fix using bolts M12x40mm (pos. 8).
5. Fix tow-ball (pos. 2) using bolts M16x50mm (pos. 6) from accessories.
6. Fix the socket plate (pos. 3) using bolt M10x30mm (pos. 9) as shown on the drawing.
7. Tighten all bolts according to the torque shown in the table.
8. Connect electric wires of 7-poles socket according to the instruction of the car. (Recommend to make at authorized service station).
9. Complete paint layer damaged during installation.

Torque settings for nuts and bolts (8,8):

M6 - 11 Nm	M8 - 25 Nm	M10 - 50 Nm
M12 - 87 Nm	M14 - 138 Nm	M16 - 210 Nm



NOTE

After install the towbar you should get adequate note in registration book (at authorised service station).The car should be equipped with:

- Indicators
- Tow mirrors

After 1000km check all bolts and nuts. The ball of towbar must be always kept clear and conserve with a grease.

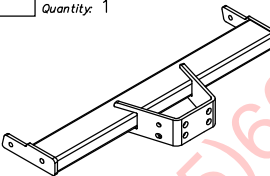
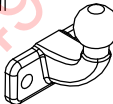
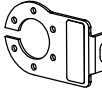
Towbar accessories:

Pos. 1	Name: Main bar Quantity: 1	Pos. 6	Name: Bolt 8,8 B Quantity: 2 Dim.: M16x50mm	Pos. 13	Name: Plain washer Quantity: 2 Dim.: Ø 17 mm
		Pos. 7	Name: Bolt 8,8 B Quantity: 8 Dim.: M12x110mm	Pos. 14	Name: Plain washer Quantity: 16 Dim.: Ø 13 mm
		Pos. 8	Name: Bolt 8,8 B Quantity: 8 Dim.: M12x40mm	Pos. 15	Name: Plain washer Quantity: 1 Dim.: Ø 10,5 mm
Pos. 2	Name: Tow ball Quantity: 1	Pos. 9	Name: Bolt 8,8 B Quantity: 1 Dim.: M10x30mm	Pos. 16	Name: Spring washer Quantity: 2 Dim.: Ø 16,3 mm
		Pos. 10	Name: Nut 8 B Quantity: 2 Dim.: M16	Pos. 17	Name: Spring washer Quantity: 16 Dim.: Ø 12,2 mm
Poz. 3	Socket plate PCS.: 1	Pos. 11	Name: Nut 8 B Quantity: 14 Dim.: M12	Pos. 18	Name: Spring washer Quantity: 1 Dim.: Ø 10,2 mm
		Pos. 12	Name: Nut 8 B Quantity: 1 Dim.: M10	Pos. 19	Name: Ball cover Quantity: 1
Pos. 4	Name: Right bracket Quantity: 1				
					
Pos. 5	Name: Left bracket Quantity: 1				
					



PPUH AUTO-HAK S.J.

Produkcja Haków Holowniczych
Henryk & Zbigniew Nejman
76-200 SŁUPSK ul. Stoneczna 16K
tel/fax (059) 8-414-414; 8-414-413
E-mail: office@autohak.com.pl
www.autohak.com.pl

Towing hitch (without electrical set)

Class: **A50-X** Cat. no. **D34**

Designed for:

MERCEDES SPRINTER

and

VOLKSWAGEN CRAFTER

Type: **3,25/3,665/4,325m, metal built-up,**

with step board, single wheels

produced since 04.2006

Approval number according to Directive 94/20/EC: e20*94/20*0208*00

Technical data:

D-value: 15,24 kN

maximum trailer weight: **2800 kg**

maximum vertical cup load: **100 kg**

Foreword

This towbar is designed according to rules of safety traffic regulations. The towing hitch is a safety component and can be installed only by qualified personnel. Any alteration or conversion of the towing hitch is prohibited and would lead to cancellation of design certification. Remove insulating compound and underseal from vehicle (if present) in the area of the matting surfaces of the towing hitch. The vehicle manufacturer's specifications regarding trailer load and max. vertical cup load are decisive for driving whereat values for the towing hitch cannot be exceeded.

D-value formula:

$$\frac{\text{Max trailer weight [kg]} \times \text{Max vehicle weight [kg]}}{\text{Max trailer weight [kg]} + \text{Max vehicle weight [kg]}} \times \frac{9,81}{1000} = D \text{ [kN]}$$